

Impeller and volute design and optimization of the centrifugal pump with low specific speed in order to extract performance curves

Amir Javanbakht ^{a, *} and Hossein Ahmadi-Danesh Ashtiani ^a

^a Department of Mechanical Engineering, South Tehran Branch, Islamic Azad University, Tehran, Iran

ARTICLE INFO

Article history:

Received: 25 November 2017

Accepted: 01 January 2018

Keywords:

Turbulence fluid flow

Centrifugal pump design

Computational fluid dynamic (CFD)

Centrifugal pump curves

Periodic boundary condition

ABSTRACT

Now a day centrifugal pumps are vital components of industries. Certainly, one of the most important specifications of centrifugal pumps are the performance curves. In the present work, performance curves of a centrifugal pumps are obtained by Computational fluid dynamics (CFD) and as an outcome, CFD results compare by practical curves. At the first step impeller and volute are designed with two standards and at the end former design completed by automatic design process using CFturbo software. For this purpose, full 3D-RANS equations in coupled with SST turbulence model are solved for several flow rate between 20% and 140% of the operation condition by means of a commercial code, CFX. This simulation is defined by means of the multi-reference frame technique in which the impeller is situated in the rotating reference frame, and the volute is in the fixed reference frame. Proposed simulation is based on a steady state flow, non-Newtonian, incompressible and constant property condition. Operation point is simulated to get the total head and then non-operation points are simulated to obtain performance curves. Practical curves and numerical ones are in good agreement, so numerical approach could be a perfect way to make centrifugal pump design better and easier. Indeed pump simulation with CFD approach can increase our knowledge about pump behavior such as consumption energy, trimming process and saving energy before we have any activities on the pump so the predictions have bettering and excise about any process on the pump.

1. Introduction

Centrifugal pumps are prevalent for many different applications in the industrial and other sectors. Nevertheless, their design and performance prediction process is still a difficult task, mainly due to the great number of free geometric parameters involved. On the other hand the significant cost and time of the trial-and-error process by constructing and testing physical prototypes reduces the profit margins of the pump manufacturers. For this reason, CFD analysis is currently being used in hydrodynamic design for many different pump types [1-3]. Numerical simulations can provide quite accurate information on the fluid behavior in the machine, and thus help the engineer to obtain a thorough performance evaluation of a particular design. However, the challenge of improving the hydraulic efficiency requires an inverse design process, in which a significant number of alternative designs must be evaluated. Despite the great progress in recent years, even CFD analysis remains rather expensive for the industry, and the need for faster mesh generators and solvers is imperative [4]. Some of the recent investigations in this field are mentioned in the

following. Thirty centrifugal pump with specific speed range of 12-160 were simulated using k-epsilon turbulence model. This simulation based on solving three dimensional Navier-Stocks equations by means of numerical approach. Total head and efficiency were extracted and validated using practical results. There is a good agreement between numerical and practical results. Some specific rule was defined and applied to numerical approach to decrease mesh independency of result [5]. A 3D-CFD simulation of the impeller and volute of a centrifugal pump was performed using CFX codes. The pump has a specific speed of 32 (metric units) and an outside impeller diameter of 400 mm. This flow simulation was carried out for several impeller blades and volute tongue relative positions. As a result, velocity and pressure field were calculated for different flow rates, allowing to obtain the radial thrust on the pump shaft [6]. Stel *et al.* presents a numerical investigation of the fluid flow in the first stage of a two-stage centrifugal pump with a vanned diffuser. Investigation of the flow pattern for different flow rates reveals that the flow becomes badly oriented for part-load conditions. In such cases, significant levels of turbulence and blade orientation effects are observed,

* Corresponding author. [e-mail: am_javan@yahoo.com](mailto:am_javan@yahoo.com)

mainly in the diffuser. In spite of different flow rates or rotor speeds, the flow pattern is quite similar if the flow dimensionless coefficient is kept constant, showing that classical similarity rules can be applied in this case. By using such rules, it was also possible to derive a single equation for the pump head to represent the whole operational range of the pump [7]. Shojaeefard *et al.* were studied the performance of centrifugal pumps drops sharply during the pumping of viscous fluids. The flow analysis indicates that with the modification of the original geometry of the pump, at the 30° outlet angle and the passage width of 21 mm, the pump head and efficiency increases compared to the other cases; this improvement is due the reduction of losses arising from the generation of eddies in the passage and outlet of the impeller [8]. Alemi *et al.* investigated the effects of the volute geometry on the head, efficiency, and radial force of a low specific-speed centrifugal pump, focusing on off-design conditions. This paper is divided into three parts. In the first part, the three-dimensional flow inside the pump with rectangular volute was simulated using three well-known turbulence models. In the second part, two volute design methods, namely, the constant velocity and the constant angular momentum were investigated. Obtained results showed that in general the constant velocity method gives more satisfactory performance. In the third part, three volutes with different cross section and diffuser shape were designed. In general, it was found that circular cross section volute with radial diffuser provides higher head and efficiency. Moreover, the minimum radial force occurs at higher flowrate in circular volute geometry comparing to rectangular cross section volute [9]. Gao *et al.* were analyzed the unsteady flow inside a large centrifugal pump with stay vanes. Considering the relative positions of the impeller to the volute tongue and stay vanes, the static performance which was obtained using a full unsteady calculation was compared with traditional steady calculation results. A comparison of the results with the experimental data showed that the operation condition farther from the design condition resulted in larger differences between the steady simulation and experimental results, with errors beyond reasonable limits, while the performance curves obtained by the unsteady calculations were closer to the experimental data. Thus, unsteady numerical simulations can be used to predict the pressure fluctuations when designing a pump [10]. Nataraj *et al.* were improved the performance of a centrifugal pump by modifying impeller design specifications via response surface methodology (RSM) complemented with computational fluid dynamics (CFD) simulations. Conformation experiments were performed to verify the optimal design specifications. Good agreements between the predicted and actual values of responses have been observed. The RSM- and CFD-based optimized impeller parameters yield an increase in total head from 39.66 m to 41.72 m and the power consumption is minimized from 432.17 W to 366.95 W at Best efficiency point (BEP) [11]. Fu *et al.* were studied cavitation in centrifugal pump. The characteristics of flow instabilities as well as the cavitation phenomenon in a

centrifugal pump operating at low flow rates were studied by experimental and numerical means, respectively. Specially, a three-dimensional (3D) numerical model of cavitation was applied to simulate the internal flow through the pump and suitably long portions of the inlet and outlet ducts. The experimental results showed that the unsteady behavior of the internal flow in the centrifugal pump operating at low flow rates has the characteristics of a peculiar low-frequency oscillation. Meanwhile, under certain conditions, the low-frequency pressure fluctuations were closely correlated to the flow instabilities induced by the occurrence of cavitation phenomena at low flow rates [12]. Wang *et al.* proposed a two-phase three-component computational model to investigate cavitation in centrifugal pump. The results show that the two-phase three-component computational model has better performance both on predicting pump head drop and bubble structure. It is observed in the current work that the sheet cavity firstly occurs on the leading edge of the suction side of the impeller. With the cavitation number decreasing, the cavity length grows rapidly along the suction side towards impeller outlet. Simultaneously, the cavity starts to extend to the pressure side [13].

In this present work, one pump design cycle including impeller and volute design, flow simulation and pump characteristic curve extraction was carried out completely. Pump flow rate in BEP is 10 m³/hr and the head rise is 10 m. electro motor rotate 2900 turn in one minute. At the first step, pump impeller was designed using CFTurbo software and the design procedure was verify using pump design standard instruction such as Guelich [14] manual. Second step allocated to design volute. Volute design using constant speed approach and at the end whole pump geometry constructed using CFTurbo. And finally, an incompressible, Newtonian, steady state and three dimensional analysis was performed to simulate pumping process. All material properties was assume constant and use water at 25°. SST model used to analyze turbulence in pump. TurboGrid was used to generate structured mesh on impeller and unstructured mesh was performed for the other components. All simulation carried out using CFX. Firstly, pump was simulated at BEP and compared numerical total head rise by the BEP head rise which pump design base on it, and then head rise, power consumption and total efficiency were obtained using 20%-140% BEP flow rate. Numerical and practical characteristic curves are in good agreement, so CFD could be efficient method to predict centrifugal pump performance.

2. pump design

Pump geometry design is divided into two major part, impeller and volute design. Impeller design is the first step and the other is volute design. At first, using defined flow rate, total rising head and rotating speed at the BEP, impeller was designed and volute designed later. Finally, impeller and volute are matched together and pump geometry was finalized. Fig.1 show the

whole process flowchart for the present work. As you see this cycle has to repeat until to reach accurate answers.

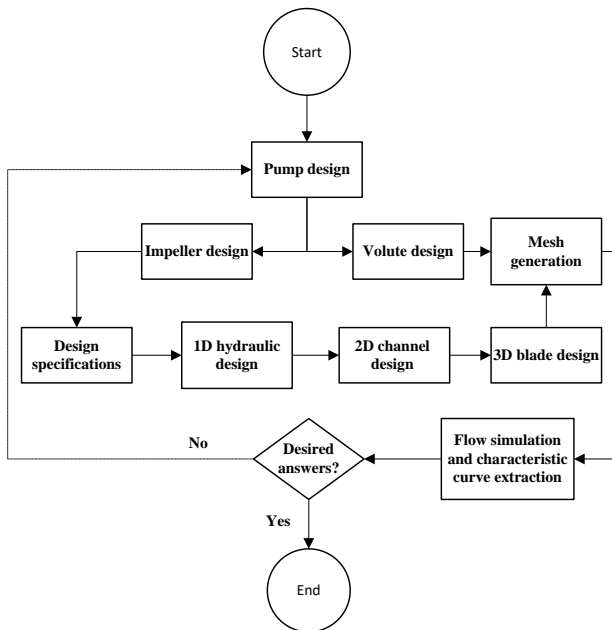

Figure 1. Pump design process flowchart

Parameters	Quantity
impeller outlet diameter	10 (cm)
Impeller outlet width	0.9 (cm)
Blade outlet angel	23°
Number of blade	5
impeller inlet diameter	4.8 (cm)
Impeller inlet width	1.7 (cm)
Blade inlet angel	15°
Blades overlap angle	72°
Volute tongue angle	35.5°
Design point flow rate	10 (m ³ /hr)
Total head rising at design point	10 (m)
Rotational Speed	2900 (RPM)
Specific speed	27.12

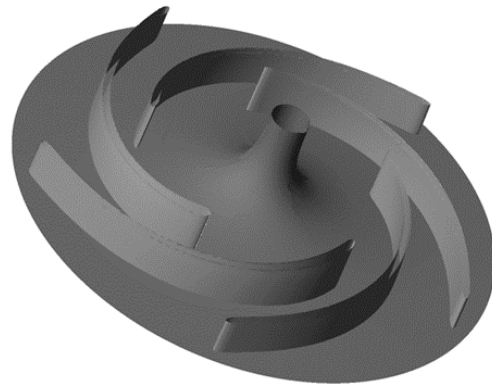

Figure 2. Impeller geometry

2.1. Impeller design

According to design point parameters and using eq.1, the pump categorize as a centrifugal pump and has the specific speed equal to 27.12. Impeller is designed according to Guelich method [14]. Basically, some matters was assumed which take into consideration as 1 to 4 below:

- 1- Flow direction is 90° at inlet-
- 2- Entrance c_{m1} is uniform
- 3- Volumetric efficiency is 90%
- 4- Impeller has 5 blade

The specific speed calculation is performed using below formula and according to that the pump is included in centrifugal pump range.

$$N_s = \frac{(N \sqrt{Q})}{H^{0.75}} \quad (1)$$

Impeller is designed based on Guelich method for centrifugal pump impeller design and the most important result of impeller geometries are listed below in Tab.1.

Parameters which are available in Tab.1 are the best designing quantity. These parameters are obtained using CFturbo software and qualify using standard. Fig.2 show the impeller geometry of pump.

Table 1: Important topology and hydrolic parameters of pump

2.2. Volute design

Three distinct theories for volute designing were presented until today:

- 1- constant speed
- 2- constant angular momentum
- 3- constant energy

Constant speed theory is the most popular one to design centrifugal pump volute. Constant speed theory has some benefits; it causes to minimize radial force as well as uniform pressure distribution around the impeller. Thus, Volute is designed based on constant speed at interior spiral cross section. Constant angular theory is used when radial force is not important and third theory was used when changing in temperature is sensible. Fig.3 display volute of pump. As it obvious, outlet cross section is circular.



Figure 3. volute of pump

3. The governing equations and numerical approach

Since the fluid surrounding the impeller rotates around the axis of the pump the equations must be organized in two reference frames, stationary and rotating reference frames. To accomplish this, the Multiple Reference Frame (MRF) model was used. In this approach, the governing equations are set in a rotating reference frame, and Coriolis and centrifugal forces are added as source terms. Eq.2 is the continuity equation and eq.3 present momentum equation. Source term in eq.3 replaced as eq.4 and mean shear stress represent as eq.5.

$$\frac{\partial u_i}{\partial x_i} = 0 \quad (2)$$

$$\rho \frac{\partial}{\partial x_i} (\overline{u_i u_j}) = -\frac{\partial \bar{P}}{\partial x_i} + \frac{\partial}{\partial x_j} (\overline{\tau_{ij}} - \rho \overline{u'_i u'_j}) + S_{u_i} \quad (3)$$

$$\overline{S_{u_i}} = -\rho \left[2\overline{\Omega} \times \overline{u} + \overline{\Omega} \times (\overline{\Omega} \times \overline{r}) \right] \quad (4)$$

$$\overline{\tau_{ij}} = -\mu \left(\frac{\partial u_i}{\partial x_j} + \frac{\partial u_j}{\partial x_i} \right) \quad (5)$$

CFX provides a powerful set of features for solving problems in which fluid rotates around an axis, such as flows inside turbomachineries in different ways. For example, these methods include multiple reference frames(MRF), mixing plane and sliding mesh models. Each method has a different accuracy and computational expenses. The first and second models are appropriate for steady flows and for cases in which the interactions between rotor and stator are negligible. For instance, for a pump with bladeless stators the MRF can be used as a suitable approach. The sliding mesh model is appropriate where the interaction between rotor and stators is noticeable and the unsteadiness of problem is supposed to be reproduced. Since in the present problem, the stator has no blade and the unsteadiness of the problem can be ignored, the MRF model was used. High resolution scheme is used to discretize continuity, momentum and turbulence equations, and also CFX default solver is adjusted to gain numerical answers. All residual for numerical solving set as 10^{-7} for RMS and 10^{-4} for maximum values. Scalable wall function was set for walls to

shift itself to logarithm wall function for small quantity of Reynolds number that this process based on y^+ for wall adjacent cell [15].

3.1. TURBULENCE MODEL

In the present work SST $k-\omega$ turbulence model was used to model turbulency of flow. The SST $k-\omega$ turbulence model is a two-equation eddy-viscosity model which has become very popular. The shear stress transport (SST) formulation combines the best of two terms. The use of a $k-\omega$ formulation in the inner parts of the boundary layer makes the model directly usable all the way down to the wall through the viscous sub-layer. The SST formulation also switches to a $k-\epsilon$ behavior in the free-stream and thereby avoids the common $k-\omega$ problem that the model is too sensitive to the inlet free-stream turbulence properties. Some former studies that SST $k-\omega$ model represented better answer than $k-\epsilon$ and RNG $k-\epsilon$ for centrifugal pumps [8]. In order to take advantage of mesh compaction near the rigid walls, the wall rule function is applied to the turbulence model equations. This function is selected in such a way that all the mesh points fall outside the viscous sub-layer.

3.2. Mesh generation and Grid independency

The pump is divided into three regions, inlet, impeller and volute. Each region is discretized independently; structured grids are used for inlet region and impeller, however an unstructured grids are used for the volute. In Fig. 4 the structured grids around impeller and unstructured ones into volute are shown. In the present study, four sets of grids were used for grid study, and the finest case was selected for the final simulation. Tab.2 shows the sets. TurboGrid (one of the Ansys sub-software which is formed to generate structured grid for rotary component of turbomachinery devices) is used to generate structured mesh for impeller and using Ansys-modeler unstructured mesh is generated for the other component of pump.

Table 2: Grid study data

Grid	Number of element
coarse	117594
normal	383113
fine	665370
finest	942847

For the improvement of accuracy, the optimum number of mesh elements in the simulation has been investigated. Also, the total head rise inside the pump for the best BEP has been used as the evaluation parameter for the effect of mesh size on the solution. Total head rise inside the pump has been calculated as eq.6 below. Finally, the relative error for total head rise, which is calculated according to eq.7, has been driven and depicted in fig.5. It can be observed that the total head change when the elements are more than 700000 is lower than 2 percent so, any grid using 700000 elements and more can be chosen. For this study, the fine grid has been chosen to simulate remnant steps of study. Grid sets are observed in Tab.2.

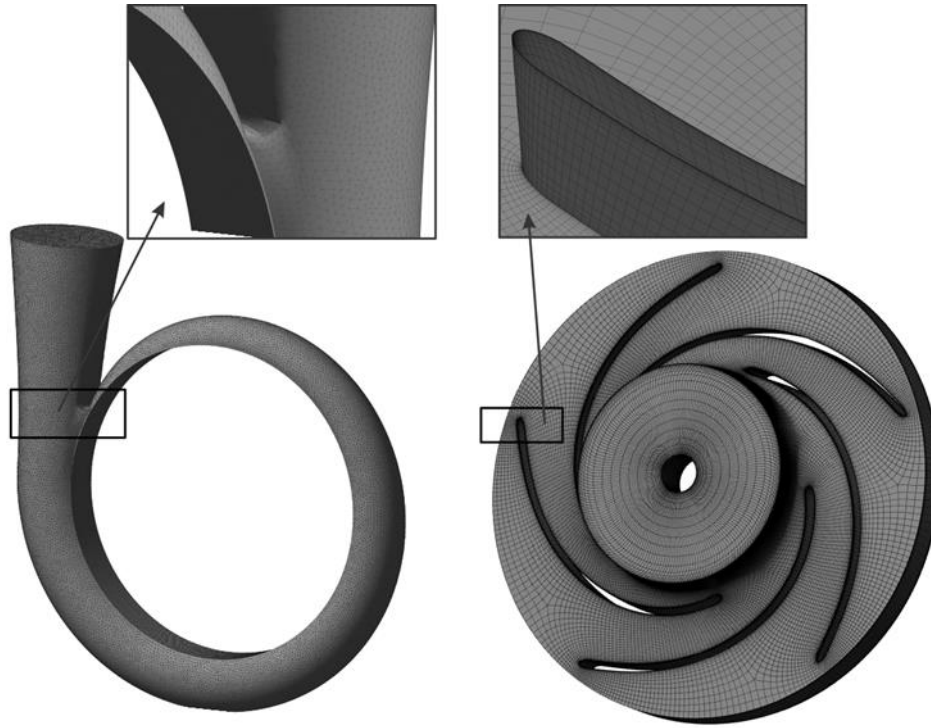

Figure 4. Structured grid for impeller and unstructured grid for volute are shown in details

$$H_{tot} = \frac{P_{tot_{outlet}} - P_{tot_{inlet}}}{\rho_{H_2O} \times g} \quad (6)$$

$$relative\ error(\%) = \frac{H_{tot_{CFD}} - H_{tot_{BEP}}}{H_{tot_{BEP}}} \quad (7)$$

In tab.3, constant values which are observed in eq.6-7 has been shown.

Table 3: Constant values of eq.6-7

Constant values	Quantity
g	9.807 m/s ²
ρ_{H_2O}	997 kg/m ³
$H_{tot_{BEP}}$	10 m

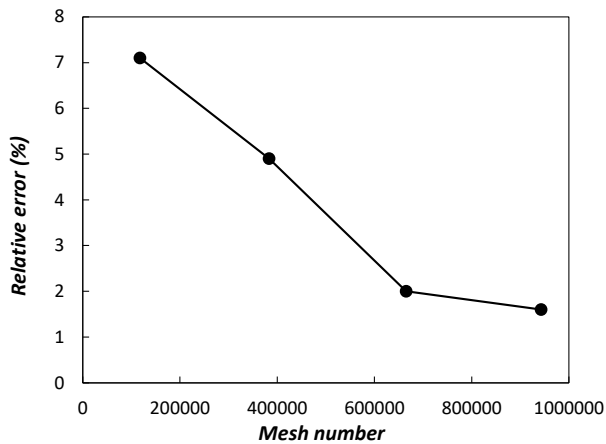

Figure 2. Relative error of total head rise against mesh element number for grid study

3.3. Boundary conditions

In the present study, only one blade has been simulated, and using periodic boundary condition for suction side of blade and adjacent blade pressure side, whole blade has been simulated. This trick could be used because flow assume as steady state without no transient effect. Using former explained trick, grid element of impeller decrease to one fifth for single blade which is so helpful to reduce calculating time. Mass flow rate and pressure outlet boundary conditions were used for the inlet and outlet, respectively. Outer walls were stationary but the inner walls were rotated by electromotor rotational speed. There were interfaces between the stationary and rotational regions. Non slip boundary conditions have been constrained over the impeller blade and walls, the volute casing and the inlet wall and the roughness of all walls is considered Inconsiderable. Turbulence intensity for all conditions is considered 1%. Water has been used as a working fluid in standard ambient condition (25°).

4. Results

The pump has been designed for BEP, therefore if operating flow rate assigned to BEP flow rate then total head rise must be equal to BEP total head rise. Using this matter and simulate designed pump at BEP and compare gained numerical total head by BEP total head. In fact, if pump design and simulation process are done by good manner, these two quantities have to

be equal, almost. Results are observed in tab.4 by more details. As it clear, numerical answer for total head rise and design head basis are so close which have 1.6% difference, relatively. After this task, simulation has been done for 20-140% of BEP flow rate, then total head rise and power consumption have been plotted against flow rate. Fig.6 is shown the total head rise curve for pump operation. It is obvious that the head curve trend reasonably.

Table 4. Comparison of CFD and actual quantity for design point

Quantity	BEP	Numerical	Relative error
Head	10 m	9.84 m	1.6%

In fact when pump was simulated using CFX, leakage and bearing friction were not modeled, thus for calculating total efficiency it is necessary to use a semi-practical function [16]. This function uses numerical data to predict total efficiency of pump according to eq.8. All parameters define in nomenclature.

$$\eta_{tot} = \left[\frac{1}{\eta_h \eta_v} + \frac{\Delta P_d}{\rho g Q H_{tot}} + 0.03 \right]^{-1} \quad (8)$$

$$\Delta P_d = \begin{cases} \frac{1.33 \times 10^{-3}}{8} \rho [2.5 \times 10^5 \omega D_2^2]^{0.124} \omega^2 D_2^5 & N'_s < 65 \\ 1.1 \times 75 \times 10^{-6} \rho g u_2^3 D_2^2 & N'_s \geq 65 \end{cases} \quad (9)$$

$$N'_s = \frac{3.65 \times N \sqrt{Q}}{H^{0.75}} \quad (10)$$

$$\eta_h = \frac{\rho g Q H_{tot}}{T \omega} \quad (11)$$

T in eq. [11] refer to shaft torque which is calculated by integration over all rotating surfaces of impeller and ω is the rotational speed in radian per second. Fig.7 show the numerical total efficiency curve. In design step, according to [14] total efficiency at BEP was calculated by eq.12:

$$\eta_{tot \text{ BEP}} = 1 - \frac{0.095}{Q^{m_1}} - 0.3(0.35 - \log_{10} \frac{N}{23})^2 \times \frac{1}{Q^{0.05}} \quad (12)$$

$$m_1 = \frac{0.1}{Q^{0.45}} \times \left(\frac{45}{N}\right)^{0.06} \quad (13)$$

Total predicted efficiency using eq.12 is equal to 55.7% for design point (BEP). Numerical result for total efficiency at BEP is 64% which it is mean that numerical solving error, design error and simplifying assumption are caused 8.3% of error. For this study, it can be appropriate approximation. In fig.7 observed which maximum quantity for total efficiency has been occurred at BEP and for another flow rates efficiency goes

down. In fact this is a predictable result because efficiency has to be maximize in BEP as its definition.

When total efficiency and total head rise curves were plotted, power consumption can be calculated using eq.9-12. Fig.8 show power consumption curve for the pump.

Fluid flow throughout impeller cause the pressure increase and these changes have plotted below fig.9.

In order to show that modeling with full impeller and one blade with periodic boundary condition implantation approximately is the same, head characteristic curve for these two situations are shown in figure 10. This comparison is investigated to adjusted result together and verify present simulation. As it is obvious for all flow rate near to BEP, head prediction for two models are appropriate. But for off design condition, calculated head for low flow rate may be predicted wrongly. But for high flow rate, head prediction is quite well. Mesh generate for whole impeller model has about 2.2 M element while, for one blade model 700 K element has been generated approximately. In this situation, running time for one blade is about one to three in comparison to the other model.

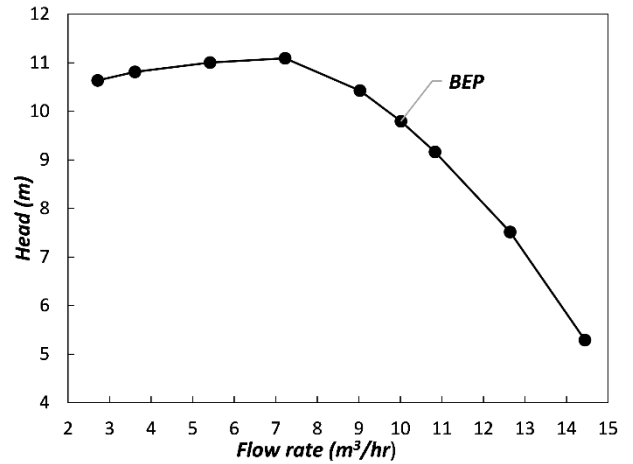

Figure 3. Total head rise for steady pump operation

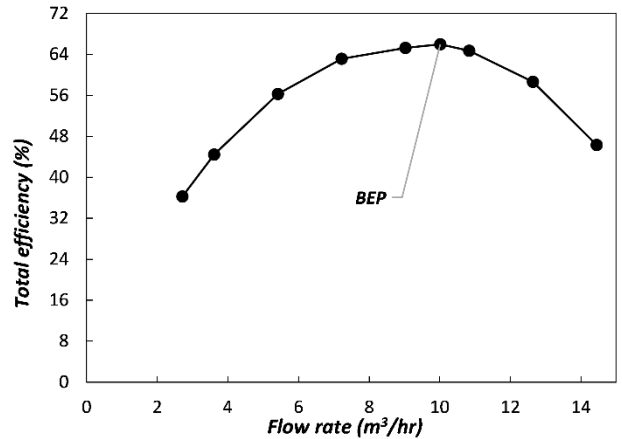

Figure 4. Total efficiency characteristic curve

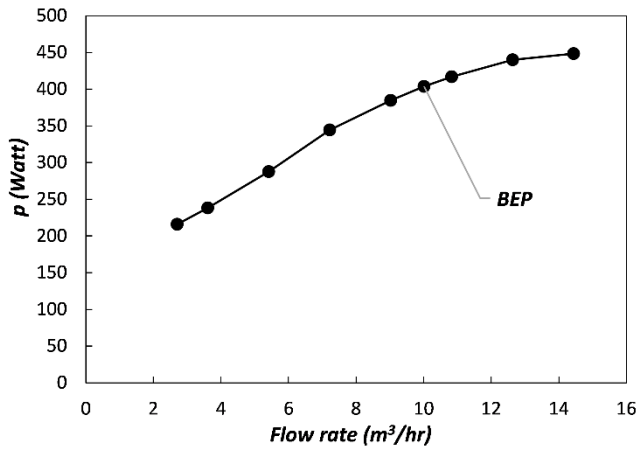

Figure 5. power consumption characteristic curve

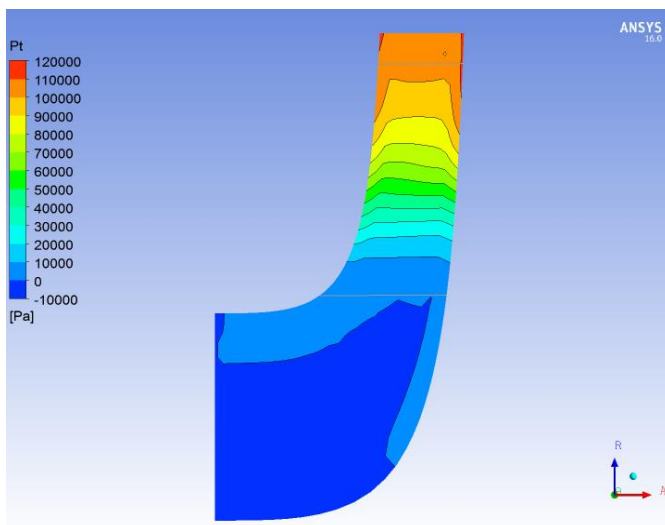

Figure 9. Pressure counter throughout the impeller

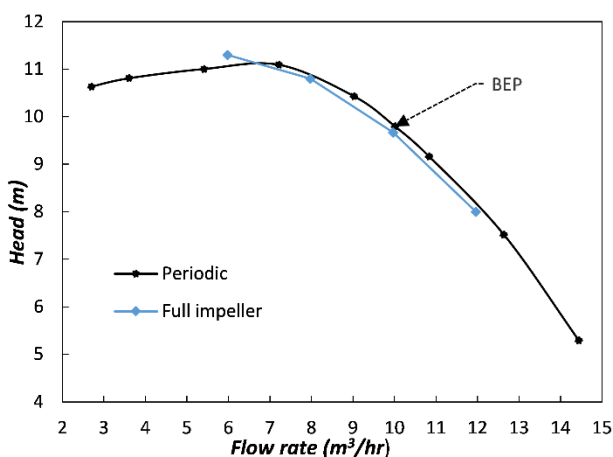

Figure 10. Comparison of two method for head characteristic curve

5. Conclusion

Present study has been investigated to extract characteristic curves of a centrifugal pump using computational fluid

dynamic. CFX commercial finite volume code was provided to do the task. At the first step using design point specification, the pump is designed using standards and its geometry is constructed with CFTurbo. Simulation is based on steady state, incompressible, three dimensional, Newtonian and constant property model. SST turbulence model is utilized to predict turbulence behavior of flow. In order to reduce computational cost, only one rotating blade in volute has been modeled and using periodic boundary condition, whole impeller has been simulated. Besides modeling one blade, whole impeller and whole pump (impeller and volute) has been modeled to investigate produced characteristic curves and compared these three curves. At design point, the internal flow or velocity vector is very smooth along the curvature along the blades. However, flow separation developed at the leading edge due to non-tangential inflow conditions.

These present work approve that, CFD is a powerful tool to predict characteristic curves of a centrifugal pump so this procedure help to understand pump behaviors. Predicted characteristic curves using three mentioned methods are in good agreement with quantity at BEP. The Predicted curves used whole pump modeling is more reliable however two other sets of curves could be helpful. The time and cost have two major parameters to distinguish which method of modeling is proper and sufficient.

Nomenclature

Gravity constant (m/s^2)	g
Total head (m)	H
Rotational speed (RPM)	N
Flow rate ($m^3.s^{-1}$)	Q
Outlet flow speed ($m.s^{-1}$)	u_2
Vertical component of velocity	C_m
Torque (N.m)	T
Specific speed	N

Greek symbols

Density ($kg.m^{-3}$)	ρ
Rotational speed ($rad.s^{-1}$)	ω
Dynamic viscosity (Pa.s)	μ
Total efficiency	η_{tot}
Hydraulic efficiency	η_h
Volumetric efficiency (assume as 90 percent)	η_v

Subscribes

Design point, Best Efficiency Point	BEP
Total	tot
Tangential component	m

References

- [1] P. Cooper, E. Graf, T. Luce, Computational fluid dynamical analysis of complex internal flows in centrifugal pumps, in *Proceeding of*, 83-94.
- [2] A. Bahreini, A. Sattari, Numerical and Economic Study of Centrifugal Pumps As Turbine Performance, *JCAMECH*, Vol. 48, No. 2, pp. 151-159, 2017.
- [3] F. A. Muggli, P. Holbein, P. Dupont, CFD calculation of a mixed flow pump characteristic from shutoff to maximum flow, *Journal of fluids engineering*, Vol. 124, No. 3, pp. 798-802, 2002.
- [4] J. González, J. Fernández, E. Blanco, C. Santolaria, Numerical simulation of the dynamic effects due to impeller-volute

- interaction in a centrifugal pump, *Journal of Fluids Engineering, Transactions of the ASME*, Vol. 124, No. 2, pp. 348-355, 2002.
- [5] J. F. Guelich, J. N. Favre, K. Denus, An assesment of pump impeller performance predictions by 3D Navier-Stokes calculations, *Proceedings of the ASME Fluids Engineering Division Summer Meeting*, 1997.
- [6] M. Asuaje, F. Bakir, S. Kouidri, F. Kenyery, R. Rey, Numerical modelization of the flow in centrifugal pump: Volute influence in velocity and pressure fields, *International Journal of Rotating Machinery*, Vol. 3, No. 3, pp. 244-255, 2005.
- [7] H. Stel, G. D. L. Amaral, C. O. R. Negrão, S. Chiva, V. Estevam, R. E. M. Morales, Numerical Analysis of the Fluid Flow in the First Stage of a Two-Stage Centrifugal Pump With a Vaned Diffuser, *Journal of Fluids Engineering*, Vol. 135, No. 7, pp. 071104-071104, 2013.
- [8] M. H. Shojaeefard, M. Tahani, M. B. Ehghaghi, M. A. Fallahian, M. Beglari, Numerical study of the effects of some geometric characteristics of a centrifugal pump impeller that pumps a viscous fluid, *Computers & Fluids*, Vol. 60, pp. 61-70, 5/15/, 2012.
- [9] H. Alemi, S. A. Nourbakhsh, M. Raisee, A. F. Najafi, Effects of volute curvature on performance of a low specific-speed centrifugal pump at design and off-design conditions, *Journal of Turbomachinery*, Vol. 137, No. 4, pp. 041009, 2015.
- [10] Z. Gao, W. Zhu, L. Lu, J. Deng, J. Zhang, F. Wuang, Numerical and experimental study of unsteady flow in a large centrifugal pump with stay vanes, *Journal of Fluids Engineering*, Vol. 136, No. 7, pp. 071101, 2014.
- [11] M. Nataraj, R. Ragoth Singh, Analyzing pump impeller for performance evaluation using RSM and CFD, *Desalination and Water Treatment*, Vol. 52, No. 34-36, pp. 6822-6831, 2014/10/15, 2014.
- [12] Y. Fu, J. Yuan, S. Yuan, G. Pace, L. d'Agostino, P. Huang, X. Li, Numerical and Experimental Analysis of Flow Phenomena in a Centrifugal Pump Operating Under Low Flow Rates, *Journal of Fluids Engineering*, Vol. 137, No. 1, pp. 011102-011102, 2014.
- [13] Y. Wang, H. Liu, D. Liu, S. Yuan, J. Wang, L. Jiang, Application of the two-phase three-component computational model to predict cavitating flow in a centrifugal pump and its validation, *Computers & Fluids*, Vol. 131, pp. 142-150, 2016.
- [14] J. F. Gülich, 2007, *Centrifugal Pumps*, Springer Berlin Heidelberg,
- [15] A. inc, Ansys CFX solver theory guide, 2014.
- [16] S. Y. M. Tan, H. Lin, Numerical Research on Performance Prediction for Centrifugal Pumps, *Chinese journal of mechanical engineering*, No. No. 1, pp. 21-28, 2010.